

GRAND AMERICAN MODIFIED RULES

*** Please refer to General Section for rules and regulations applicable to all divisions***

CNS Reserves the right to alter or amend the Rules and Regulations in the interest of safety, cost control, and / or fair competition. ADDING WEIGHT, REQUIRING THE LOSS OF LEFT SIDE PERCENTAGE, OR REQUIRING A CARBUERATOR RESTRICTION PLATE ON A VEHICLE, WILL BE TOOLS USED BY CNS OFFICIALS TO MAINTAIN FIAR COMPETITION. It is the responsibility of each competitor to read and understand the contents of these Rules. If there is a disagreement or dispute regarding the meaning or application of these Rules, the decision of the Track Steward shall prevail.

GRAND AMERICAN MODIFIED TEMPLATE INSTALLATION GUIDELINES

| Letter | Max. | Min. |
|--------|--|-------------------------------------|
| A. | N/A | 108" |
| B. | 38" | 28" |
| C. | 48" | 34" |
| D. | 120" | 106" |
| E.* | 72" Or Past Back of Block | |
| F. | 31" | 22" |
| G. | 52" | 42" |
| H. | 18" | 12" Vert. Opening |
| I.**** | 68" | 53" |
| J. | 52" | 44" |
| K. | 56" | 41" |
| L. | LEFT REAR TIRE MUST BE PARTIALLY OUTSIDE BODY AND NERF BAR, AND VISIBLE FROM FRONT, REAR, AND TOP. | |
| M. | DRIVER'S COMPARTMENT MUST BE TOTALLY SEALED FROM ENGINE AND RACE TRACK. | |
| N.*** | 8" MIN / WITHIN 2" FROM 90° ANGLE | |
| O. | 20" | 16" FROM GROUND TO CENTER OF BUMPER |

Body Cannot go further forward than block

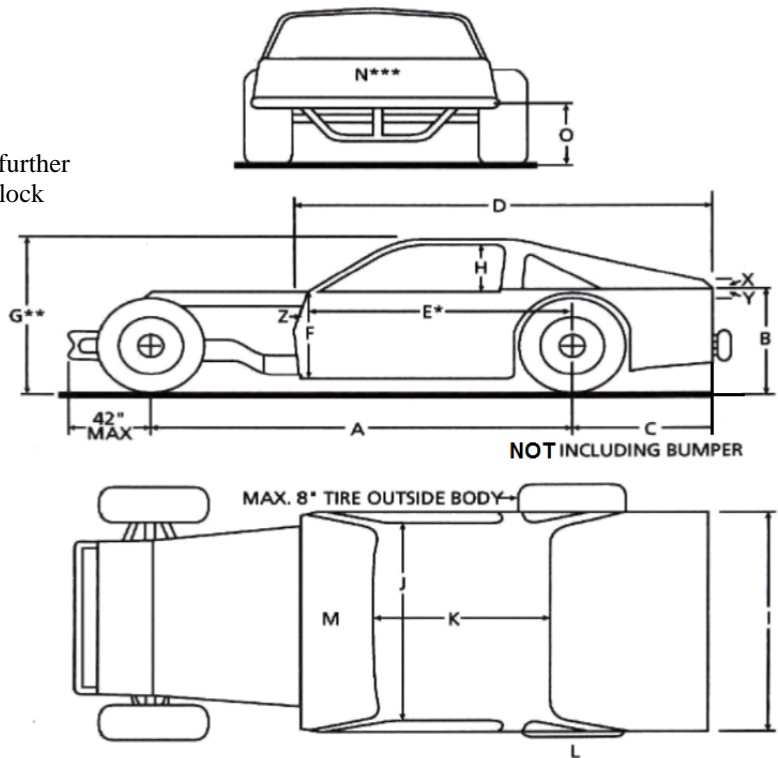

- X. MUST HAVE GRADUAL SLOPE FROM ROOF TO THIS POINT
- Y. 4" MAX INTERIOR SLOPE FRONT TO REAR. SEE "Z" ON CAR DIAGRAM.
- Z. INTERIOR SLOPE IS 6" FRONT TO REAR AND FLAT ACROSS. IF YOU STAY FLAT THE FRONT HALF OF THE INTERIOR, YOU HAVE USED UP TO 50% OF YOUR 4" SO FROM BEHIND DRIVER TO REAR YOU MAY USE ONLY 2". ALSO, THE TOP OF THE INTERIOR MUST BE FLUSH WITH THE TOP OF THE DOOR AND QUARTER PANELS. AN OPTIONAL ESCAPE HATCH RIGHT SIDE MAY BE USED BY BRINGING THE METAL FROM THE TOP OF RIGHT DOOR DOWN DRIVER'S COMPARTMENT NO HIGHER THAN 12" FROM FLOOR PAN. FRONT AND REAR HATCH MUST BE 90 DEGREE ANGLE TO INTERIOR.
- * RIGHT SIDE. LEFT SIDE MAY EXTEND FORWARD TO COVER FOOT BOX.
- ** ROOF RAKE USING FOUR FOOT LEVEL. MUST HAVE LESS THAN 2" CLEARANCE AT REAR OF ROOF AND 1/2 - 5" AT FRONT
- *** REAR PANEL MUST BE SOLID AND ATTACH TO DECK AND EXTEND TO QUARTER PANELS AND BE SECURELY FASTENED.
- **** All horizontal body surfaces will be measured to calculate body interior width. No wider than 68" max at bottom.
- ***** Both Sides of body may not have any more than 1.250" gap in center of body when a **string straightedge** is used front to rear.
- LEXAN MAY BE USED IN 1/4" WINDOWS ONLY!

Body Mounting:

The Preceding picture and definition will be used as a general guide for the purposes of determining legality of the body. Doors and quarter panels must be parallel from side to side, with no tapering from the front to rear allowed.

Sail panels must be the same on both sides of the body and in the same location (plus or minus 2 inches)

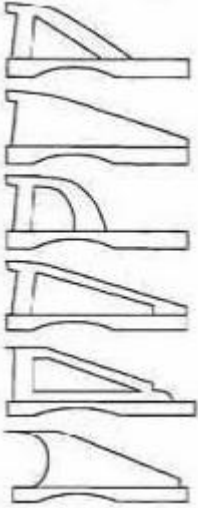

Maximum Bow – 4 inches

1. THE CAR, BODY, AND SPOILERS

- 1.1 Deleted.
- 1.2 Deleted.
- 1.3 Deleted.
- 1.4 No side windows.
- 1.5 Body parts may be constructed of steel, aluminum, or fiberglass. No Carbon Fiber. Paint is not required.
- 1.6 No wings or any other ground effects are allowed anywhere outside or inside of the car. No Panning on any part of the body or chassis. **No pans or air deflectors allowed under body or chassis.**
- 1.7 Engine compartment will remain open, No side panels are allowed.
- 1.8 Hood sides may have a maximum 4 inch drop and a maximum of a 3 inch rake and be sealed off from the driver's compartment.
- 1.9 Body is not to extend farther forward than back of engine block.
- 1.10 All forced air openings must be used for radiator or brake cooling only.
- 1.11 Driver and passenger side windows must have at least 12 inch vertical opening.
- 1.12 All cars must be equipped with approved side rail bars and scrub rails.
- 1.13 Side kick-offs must extend to the outside of the rear tires one inch and taper inward to the body toward the front of the car.
- 1.14 Front bumper must be made of 2 pieces of 1-3/4 inch max tubing, 4 to 6 inches apart, with 2 vertical connectors, mounted to front frame rails at spindle height. 50" width max.
- 1.15 Front Bumper can be no wider than the front frame rails.
- 1.16 Rear bumper must not extend beyond the width of the rear tires.
- 1.17 The rear bumper can be no more than 4 inches wider than body.
- 1.18 May be constructed of tubing or flat stock, no sharp edges
- 1.19 The center of the bumpers, front and rear, must be 18 inches (plus or minus 2") from the ground.

- 1.20 A rear spoiler, non-adjustable by the driver may be attached to the rear deck-lid.
- 1.21 The spoiler may not to exceed 4 inches in height and 240 sq. inches.
- 1.22 It must be 1/8 inch metal or 1/4 inch Lexan and control the flow of air over one surface only.
- 1.23 A maximum of three 1-inch wide supports may be installed on the rear spoiler. No rudders or forward mounting brackets allowed.
- 1.24 Nose width 45.5 inches max. 1" max wicker on nose allowed. Wicker must run front to back. 3" max extension in front of bumper.
- 1.25 TAR and 5Star Bodies with windows allowed.
- 1.26 Roof height will be measured 10" back from the front windshield opening.

2. WINDSHIELD, GLASS, AND MIRRORS

- 2.1 Front and rear Lexan windshields are recommended.
- 2.2 No colored/tinted Lexan, decals, or graphics allowed on front or rear windshield areas.
- 2.3 3 - 5/16" steel bars evenly spaced and securely mounted in front of driver are required.
- 2.4 Rear view mirror with a maximum width of 26 inches will be permitted.
- 2.5 Front edge of roof or windshield is reserved for series sponsor decal. This is mandatory to receive points.

3. FRAMES

- 3.1 1970 or newer, American made, passenger car frames only.
- 3.2 Frame may be cut in rear only at a point not further than 36 inches from center of rear-end housing.
- 3.3 Frame may not be widened or narrowed, must be full and complete on both sides.
- 3.4 Front cross member may be notched for radiator clearance only.

4. ROLL BARS

- 4.1 All cars must have a steel roll cage consisting of continuous hoop not less than 1-3/4 inch outside diameter and must have a wall thickness of at least .095.
- 4.2 Cage must be mounted in at least six places with proper bracing to protect the driver.
- 4.3 Earnhardt bar is recommended; a vertical support down tube from upper halo to cage to add support to upper halo.
- 4.4 Minimum of three driver side door bars, parallel to the ground and perpendicular to the driver and welded to front and rear of roll cage.
- 4.5 Bar across back of engine with vertical rub rails for protection of feet is required.
- 4.6 Steel door plate, must be securely welded to outside of driver side door bars and cover area from top door bar to bottom door bar and from rear hoop down-post to five inches in front of seat.
- 4.7 No brace bars forward of cage may be higher than stock hood.
- 4.8 Down bars cannot pass through the hood.

5. ENGINE SPECIFICATIONS

- 5.1 CNS uses an open Engine Rule. All engines must start under their own power. No aluminum blocks. No V-6 engines.
- 5.2 No dry sump oil systems.
- 5.3 Engine must be at least 72 inches from the back of the block to the center of the rear end housing.
- 5.4 A maximum of 2 inch offset allowed.

6. EXHAUST

- 6.1 Mufflers are mandatory - 95 DBA OR LESS WILL BE STRICTLY ENFORCED!
- 6.2 Exhaust must extend under the car and behind the driver and be securely mounted.
- 6.3 Heat shields to cover exhaust system can be no more than 4 inches wide and no longer than the valve covers.

7. CARBUREATOR

- 7.1 CNS uses an open carburetor rule. See general rules for air filter requirements.

8. IGNITION

- 8.1 Only a point type, single or dual, or electronic system is permitted.
- 8.2 No magnetos or computerized systems are allowed.
- 8.3 The distributor must mount in the stock location and maintain the same firing order as a factory produced engine for the make and model engine being used.
- 8.4 No crank trigger ignition systems allowed.
- 8.5 No adjustable timing controls allowed.
- 8.6 No ignition system equipment or wiring may be located in the driver's side door area.
- 8.7 All ignition system equipment must be securely mounted, with an unobstructed view, and to the driver's right.
- 8.8 All wires from MSD to distributor must be visible with NO open connections.
- 8.9 Cell phones, smart watches, and / or Bluetooth devices will not be allowed in the racecar at anytime during qualifying or race.

9. COOLING SYSTEM

- 9.1 Cooling system may be modified.
- 9.2 Radiator and oil coolers must not protrude above interior.
- 9.3 Minimum 2-quart catch can, must be securely mounted.

10. TRANSMISSION

- 10.1 No 5 speed transmissions or "in and out" boxes allowed.
- 10.2 Automatic transmissions are allowed.
- 10.3 No transmission gear may be closer than 1.23:1 of the final drive ratio of 1:1.
- 10.4 Internal clutch transmissions are allowed – such as Bert and Brinn.

11. CLUTCHES

- 11.1 Aluminum or light alloy clutch assemblies are allowed.
- 11.2 No carbon or carbon fiber clutches are allowed.

12. DRIVE SHAFTS

- 12.1 No aluminum or carbon fiber drive shafts, yolks, or slip yolks allowed.
- 12.2 Driveshaft must have a 360-degree drive shaft loop and must be constructed of at least (1) 0.25 inch by two inch steel, or one inch tubing, mounted six inches back from front U-Joint preventing the shaft from being dislodged and dropping onto the racing surface.

13. REAR END

- 13.1 Any passenger car or truck type rear-end is permitted.
- 13.2 Quick change rear ends are allowed provided steel tubes and mounts are used.
- 13.3 Full spool, mini spool or welded rear ends only.
- 13.4 No open or unlocked rear ends.
- 13.5 Aluminum lowering blocks, axle caps, and drive plates are allowed.
- 13.6 No cambered rear-ends or titanium axles or lower shafts are allowed.
- 13.7 No rear sway bars are allowed.
- 13.8 Locking devices like Gold Tracs are NOT allowed.
- 13.9 Final drive ratio must be a maximum of 5:67.

14. BRAKES

- 14.1 Working calipers or drums on all four wheels is required.
- 14.2 OEM type brake parts only.
- 14.3 No carbon fiber. No titanium.
- 14.4 No aluminum calipers.
- 14.5 No aluminum components.
- 14.6 Rotors cannot be lightened or drilled. Must be OEM or OEM replacement; minimum width .800 for front brakes 11" diameter.
- 14.7 No solid-type rotors allowed.
- 14.8 Racing type brake pedals and master cylinders permitted.
- 14.9 Brake bias adjustments or adjuster valves are permitted.
- 14.10 Two piece steel rotors and hubs are permitted as long as they are not drilled.

15. TREAD WIDTH

- 15.1 81 inches maximum, measured from the outer most part of the tire at spindle height, zero tow in, front and rear as presented for inspection –No tolerance. Must fit CNS gauges.

16. WHEEL BASE

- 16.1 108 inch minimum

17. SUSPENSION

- 17.1 Must be unaltered OEM stock replacement in stock location and must be replaceable by stock parts from same type.
- 17.2 Lower A-frames cannot be moved.
- 17.3 Tube type steel upper A-frames permitted.
- 17.4 Aluminum cross shafts permitted. IMCA approved aluminum coil over kit is legal.
- 17.5 Heim joints and steel sleeves and mono balls will be permitted on the front suspension provided the component is not modified to accommodate use.
- 17.6 Hubs and A-frames cannot be made of aluminum; any other aluminum suspension parts are also not allowed.
- 17.7 No fiberglass suspension parts allowed.
- 17.8 Any type of front sway bar is optional.
- 17.9 No weight changing devices to be mounted so that they may be operated from inside of the car.

- 17.10 Ford strut cars may thread or modify frame end of strut. Bearing mounted strut is allowed.
- 17.11 Any ball joint will be allowed.

18. SPINDLES

- 18.1 Stock passenger car spindles only. No welding, grinding, bending, fabrication of spindles allowed.
- 18.2 Aluminum spindles not allowed.
- 18.3 No drop spindles.

19. STEERING

- 19.1 Steering box must remain within one original bolt pattern for type of frame used.
- 19.2 No rack & pinion steering.

20. SHOCKS / SPRINGS

- 20.1 No aluminum shocks allowed.
- 20.2 Only one shock per wheel.
- 20.3 Only shocks that are cataloged from a reasonably recent period at less than \$300.00 racer's net are allowed. It is the responsibility of the Driver / Owner to prove the cataloged pricing upon request from a CNS Official. Failure to provide the requested pricing will result in disqualification.
- 20.4 Coil springs a minimum of 4-1/2 inches in diameter permitted on the front or rear of the car.
- 20.5 No torsion bars in rear allowed.
- 20.6 Bump Stops and Bump Springs are allowed.
- 20.7 A 3rd link spring bar with minimum 5" spring allowed; must be all steel.
- 20.8 Biscuit Bar on right side trailing arm allowed; must be all steel.

21. WHEELS & TIRES

- 21.1 8.0 inch steel approved racing wheels are mandatory.
- 21.2 Mandatory track tire will be a Hoosier 970 series tires.
- 21.3 All tires must be purchased at CNS and will be marked, if a driver is found to be using tires that have not been marked, they will be automatically disqualified for the evening with a minimum loss of points and prize money.
- 21.4 All competitors are allowed to purchase up to 4 new tires (2 right side and 2 left side) and must run those four tires for BOTH qualifying and competition (Dash & Feature Races) for three consecutive nights of racing.
- 21.5 Tire rules subject to change upon level of competition per CNS Official's discretion.
- 21.6 Wheel adapters made of steel or billet aluminum are allowed, up to 2 inches on rear only.
- 21.7 No cast aluminum adapters allowed.

22. WEIGHT: *Weight must be posted on the Passenger A-Pillar!*

- 22.1 All cars prior to a race shall weigh no less than 2575 pounds and no more than 58% left side weight. This includes engine requirement weight penalty if applicable.
- 22.2 Deleted.
- 22.3 Deleted.
- 22.4 Weight rules are subject to change per level of competition at CNS Officials discretion.

- 22.5 All cars must be able to cross over the scales without any part of the frame or body touching the scale or ramps. You will not be allowed on track if it hits. If a car is deemed to repeatedly contact the racing surface it will be black flagged with the corresponding finish.
- 22.6 All ballast must be lead and painted white, and car number must be identified on all lead including in lead rail.
- 22.7 602 crate motor option: weight is 2,500lbs.
- 22.8 Fab stub rule tabled until 2025. If a driver wishes to compete with a Fab stub in 2024, the car will be evaluated & approved on an individual basis (amount and location of weight placement, etc.).

23. FUEL

- 23.1 Only racing fuel will be permitted and must be purchased from CNS directly.
- 23.2 Alcohol will be allowed provided a minimum of a six inch letter "A" is affixed at the rear of the side door numbers for emergency crew identification.
- 23.3 Racing fuel shall not be blended with any other gasoline or any additives, nitro compounds, or other oxygen containing compounds. It is the competitor's responsibility to ensure that fuels are not mixed in previously used containers.
- 23.4 Icing or cooling of fuel system will not be permitted in the pit or racing areas.
- 23.5 Icing, Freon type chemicals, or refrigerants may not be used in or near the fuel system.
- 23.6 Pressure systems will not be permitted.
- 23.7 Any concealed pressure type containers, feed lines, or actuating mechanisms will not be permitted, even if inoperable.
- 23.8 Only 1 gasoline filter may be used between the fuel cell and the fuel pump. The location and size of the filter must be acceptable to CNS officials.
- 23.9 No nitrous oxide or additives of any kind allowed.

24. FUEL CELL

- 24.1 The use of a racing fuel cell is required, and must be mounted by at least two steel straps 2 inches wide around the cell.
- 24.2 Fuel cells must be enclosed in metal container, and must also be protected in rear with roll-cage tubing and securely mounted behind the rear-end.
- 24.3 Fuel cell height 9 inches minimum measured to bottom of cell from ground with driver inside.
- 24.4 No part of fuel cell should be lower than protective tubing.
- 24.5 Fuel cells must be vented out upper left rear corner with a flapper or check valve in the vent tube.
- 24.6 No glass or plastic fuel filters are allowed.
- 24.7 A reinforcement plate of not less than 1/8 inch magnetic steel must be installed behind the fuel cell. Plate must be welded to cage and must extend the entire width and height of the fuel cell.
- 24.8 Steel braided fuel lines or lines sealed in pipe or conduit are required.
- 24.9 Oberg or SRI antisiphon valve is mandatory; mounted near fuel cell after fuel filter.

OUT OF TOWN CARS

CNS invites all Out of Town competitors. Due to differing levels of competition, CNS reserves the right to adjust gear, total weight or bias on an individual basis.